

WIRELESS CONNECTION WITH INTEGRATED TRANSMITTER



RADIO MOBILE



Wireless transmission systems for safety edges.



WIRELESS CONNECTION WITH EXTERNAL TRANSMITTER

APPLICATIONS

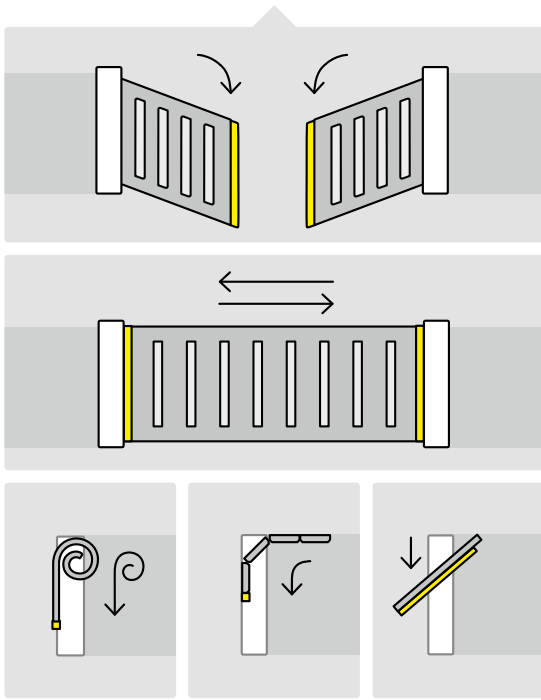

SIZES

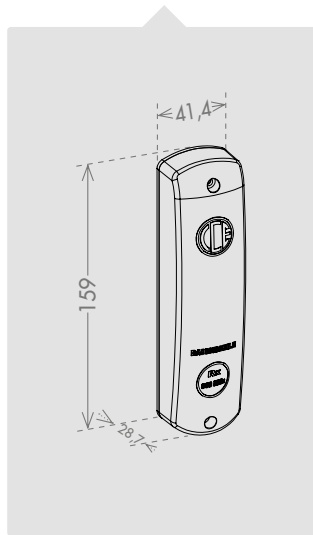

IT RADIO MOBILE è un dispositivo di comunicazione wireless per la gestione in sicurezza di uno o più bordi sensibili. Applicabile a tutti i tipi di bordo, risparmia laboriosi cablaggi.

UK RADIO MOBILE is a bidirectional wireless communication system used to manage one or more safety edges. The system is easy to install without any laborious wiring on the moving parts.

FR RADIO MOBILE est un dispositif de communication sans fil pour la gestion en sécurité d'un ou plusieurs bords sensibles. Il est applicable à tous types de bords sensibles et évite les câblages laborieux.

DE RADIO MOBILE ist eine Funkanlage für das sichere Ansteuern einer oder mehrerer Kontakteisten. Sie ist für alle Arten von Kontakteisten verwendbar und erspart arbeitsaufwändiges Verkabeln.

ES Radiomobile es un dispositivo de comunicación inalámbrico que controla uno o varios bordes sensibles con toda seguridad. Instalable en todo tipo de bordes, evita el engorro del cableado.

RADIO MOBILE RX 868 MHz

code: **RADIORX868**



RADIO MOBILE TX 868 MHz

code: **RADIOTX868**



LEGENDA

APPLICAZIONI / APPLICATIONS APPLICATIONS/ ANWENDUNGEN / APLICACIONES

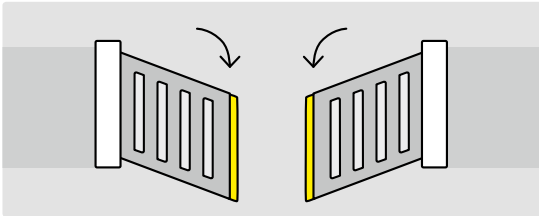

Cancelli a battente.
Swing gates.
Portails battants.
Schwenktore.
Puertas de hoja batiente.

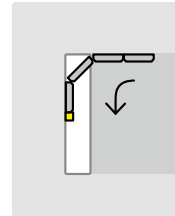

Portoni sezionali.
Sectional doors.
Portes sectionnelles.
Sektionaltore.
Portones seccionales.

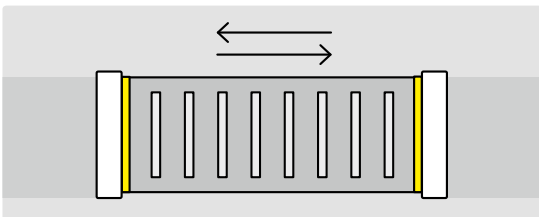

Cancelli scorrevoli.
Sliding gates.
Portails coulissants.
Schiebetore.
Puertas correderas.

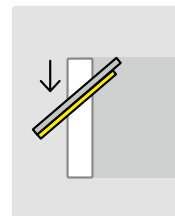

Portoni basculanti.
Overhead doors.
Portes basculantes.
Kipptore.
Portones basculantes.

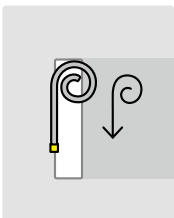

Serrande.
Rolling shutters.
Rideaux.
Rolltore.
Puertas enrollables.

CARATTERISTICHE GENERALI / GENERAL SPECIFICATIONS CARACTERISTIQUES GENERALES / ALLGEMEINE DATEN / CARACTERÍSTICAS GENERALES

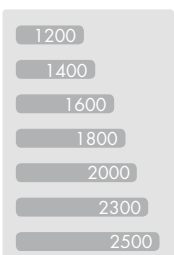

Lunghezze disponibili.
Available lengths.
Longueurs disponibles.
Verfügbare Längen.
Largos disponibles.

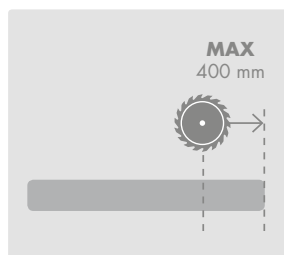

Accorciabilità massima.
Maximum trimming lengths.
Raccourcissement maximum.
Maximale Ablängbarkeit.
Recorte máximo posible.



Temperatura di esercizio.
Working temperature.
Température de fonctionnement.
Betriebstemperatur.
Temperatura de funcionamiento.



Grado di protezione microinterruttori.
Microswitch degree of protection.
Indice de protection des micro interrupteurs.
Schutzart Mikroschalter.
Grado de protección de los microinterruptores.

CARATTERISTICHE MODELLO / MODEL SPECIFICATIONS CARACTERISTIQUES PRODUITS / MODELLSPEZIFISCHE DATEN CARACTERÍSTICAS DEL MODELO



Contatto normalmente aperto (N.A.)
Normally open contact (N.O.)
Contact normalement ouvert (N.O.)
SchlieÙerkontakt (N.O.)
Contacto normalmente abierto (N. A.)



Contatto normalmente chiuso (N.C.)
Normally closed contact (N.C.)
Contact normalement fermé (N.F.)
Öffnerkontakt (N.C.)
Contacto normalmente cerrado (N. C.)



Dispositivo di sicurezza resistivo.
Resistive safety edge.
Dispositif de sécurité résistif.
Widerstands-Schutzvorrichtung.
Dispositivo de seguridad resistivo.



Certificato IMQ.
Certificated by IMQ.
Certificat IMQ.
Zertifiziert durch IMQ als Prüfinstitut.
Certificación IMQ.



Portata massima in campo aperto.
Open field maximum range.
Portée maximum en champ libre.
Maximale Reichweite ungestört.
Alcance máximo en campo abierto.



Canali di trasmissione.
Nr. of transmission channels.
Canaux de transmission.
Übertragungskanäle.
Canales de transmisión.



Comanda fino a ... TX.
Controls up to ... Tx.
Contrôle jusqu'à ... TX.
Betätigung von bis zu ... Sendern.
Controla hasta ... TX.



Alimentazione con batterie al litio 1,5 V.
1,5V lithium batteries transmitter power supply.
Alimentation par piles au lithium 1,5 V.
Stromversorgung durch Lithiumakkus 1,5 V.
Alimentación con pilas de litio de 1,5 V.



Alimentazione 12/24 v AC/DC.
12/24 v AC/DC Power supply.
Alimentation 12/24 v AC/DC.
Betriebsspannung 12/24V AC/DC.
Alimentación: 12/24 VCA/VCC.



Frequenza di trasmissione.
Transmission frequency.
Fréquence de transmission.
Übertragungsfrequenz.
Frecuencia de transmisión.



Collegamento in serie di più coste conduttive.
Series wiring of several conductive safety edges.
Installation de plusieurs palpeurs conducteur en série.
Reihenschaltung mehrerer Kontakteleiste
Conexión en serie de mas dispositivos CND.

OPZIONI / OPTIONALS OPTIONS / OPTIONEN / OPCIONES



Scheda di controllo.
Control boards.
Carte de contrôle.
Steuerkarte.
Tarjeta de control.

OPT



Coppia trasmettitore + ricevitore wireless.
Wireless receiver&transmitter.
Couple transmetteur et récepteur sans fil.
Funk-Sender-/Empfängeranlage.
Conjunto de transmisor + receptor inalámbrico.

OPT



Ricevitore wireless.
Wireless receiver.
Récepteur sans fil.
Funkempfänger.
Receptor inalámbrico.

OPT