

Lavorazione da eseguire su entrambi gli spigoli inferiori dell'anta

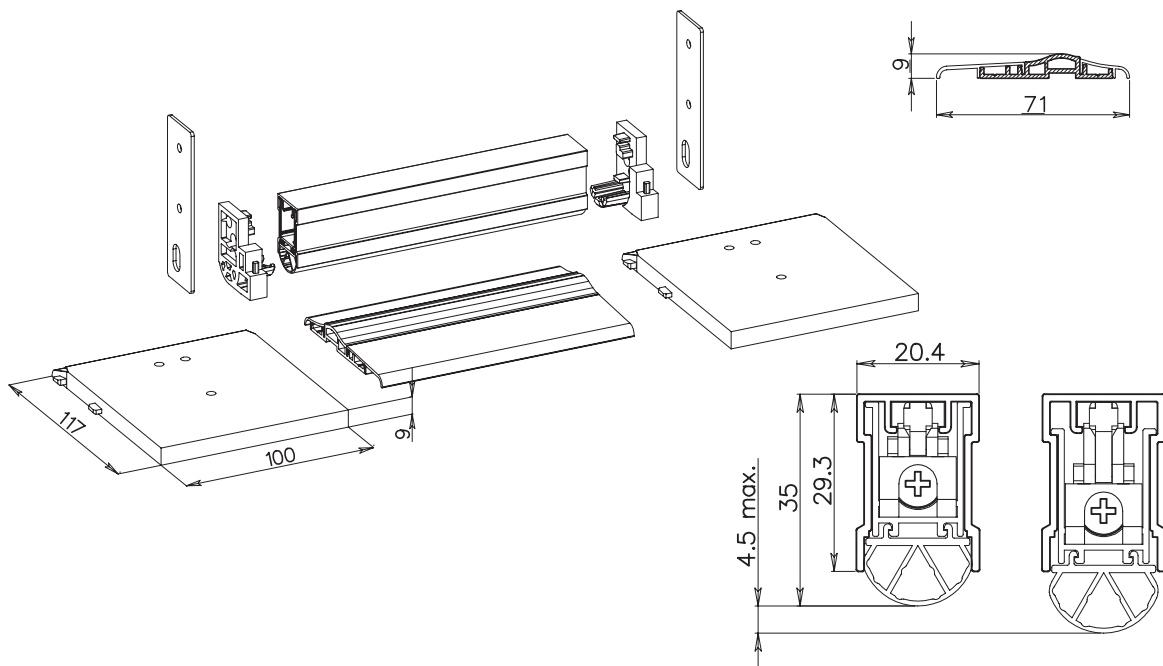

1

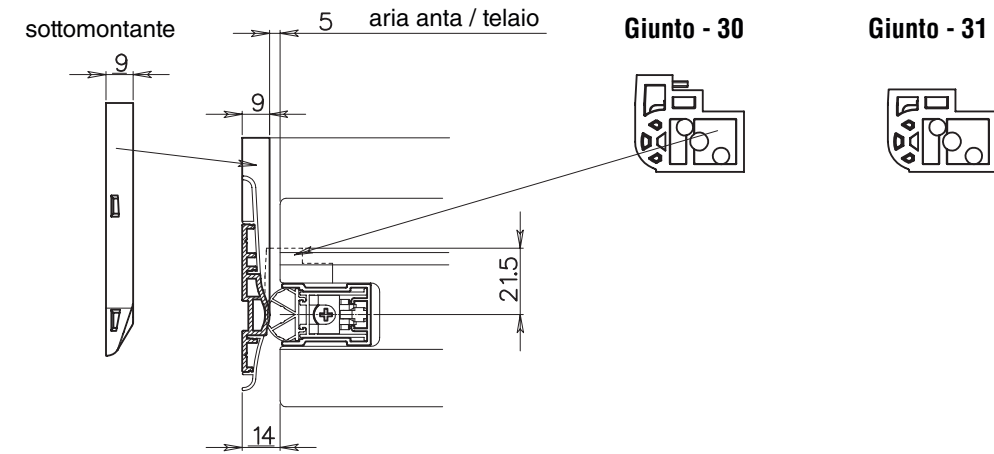
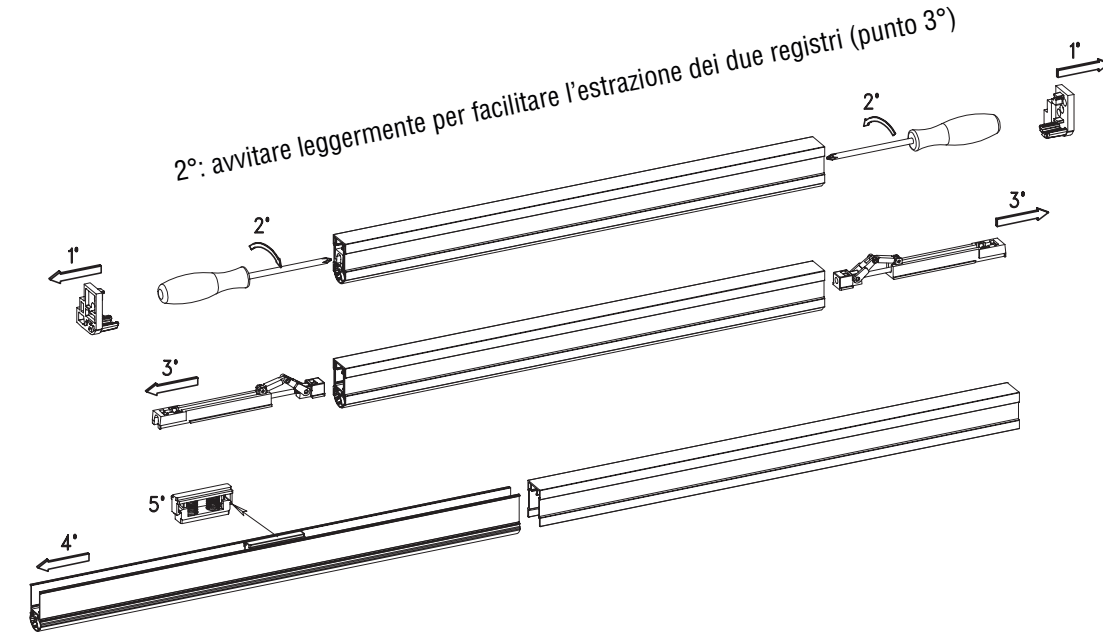

2

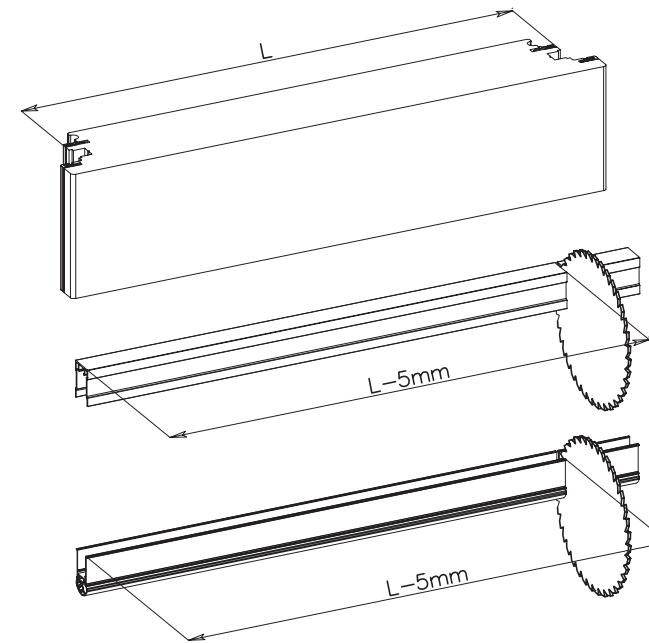

3

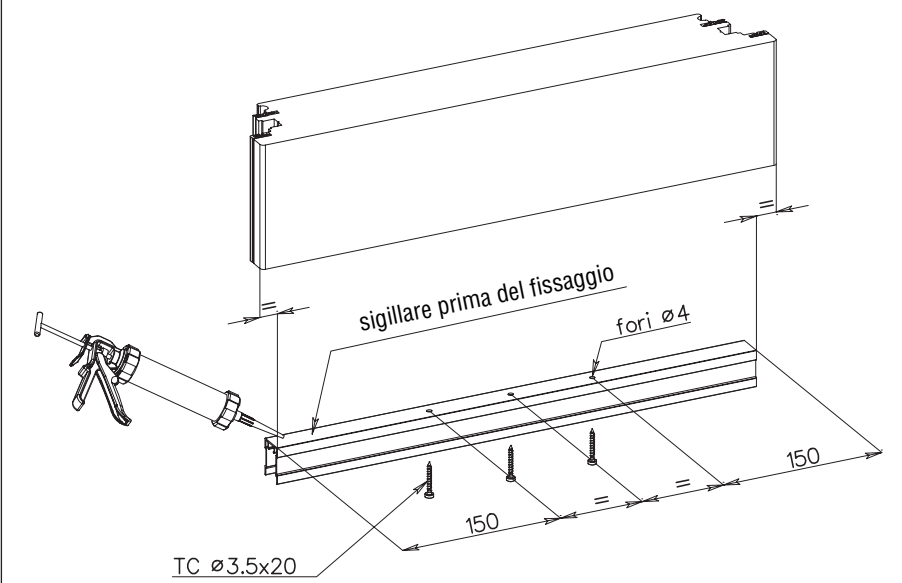

4

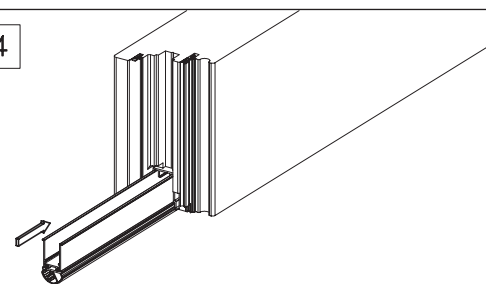

5

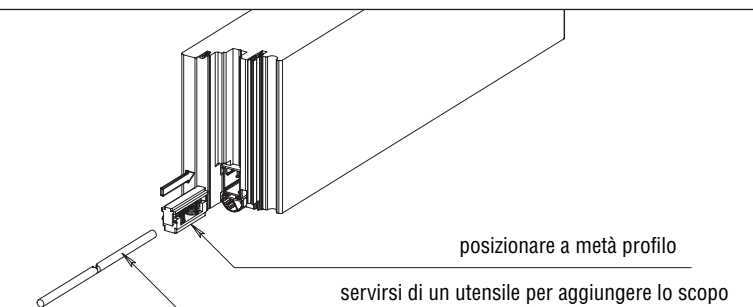

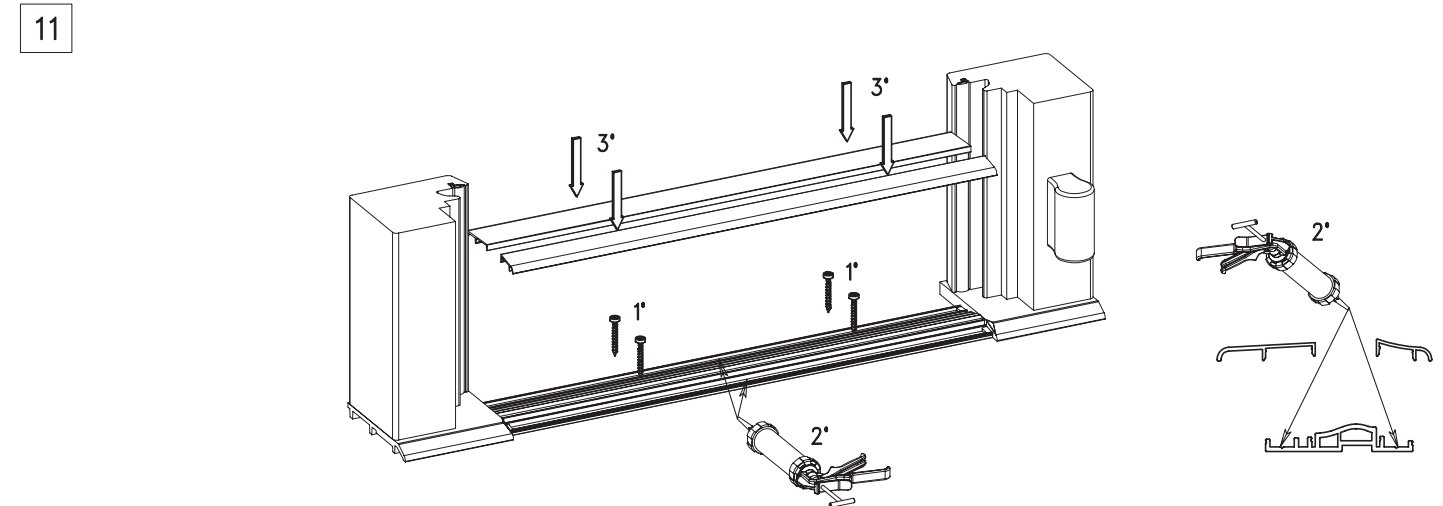
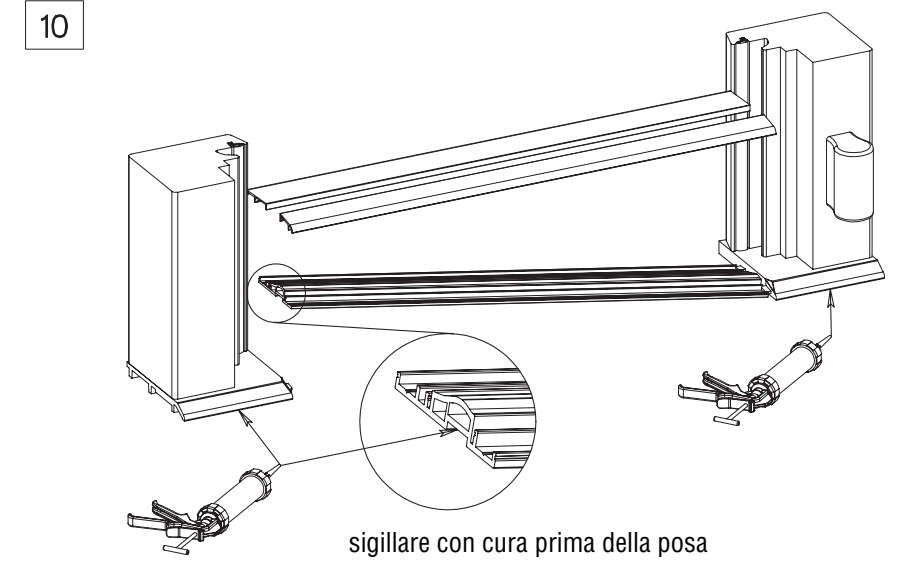
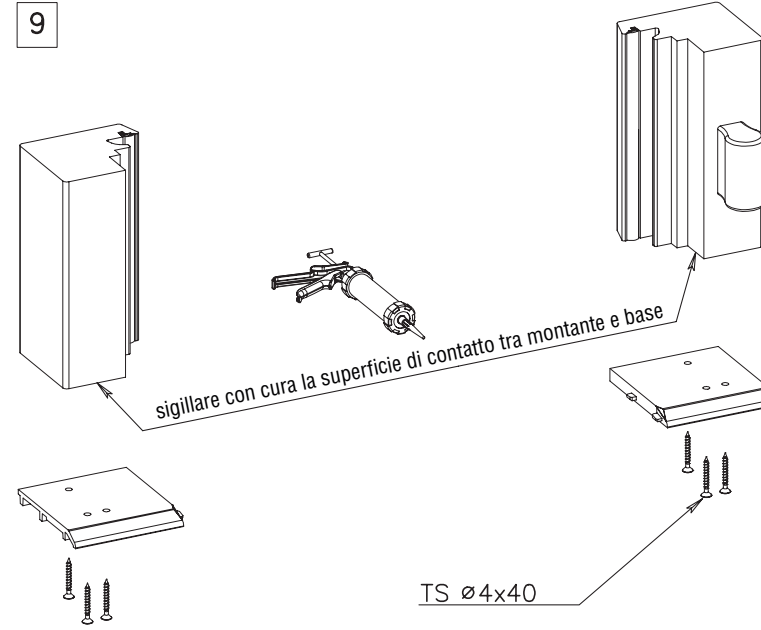
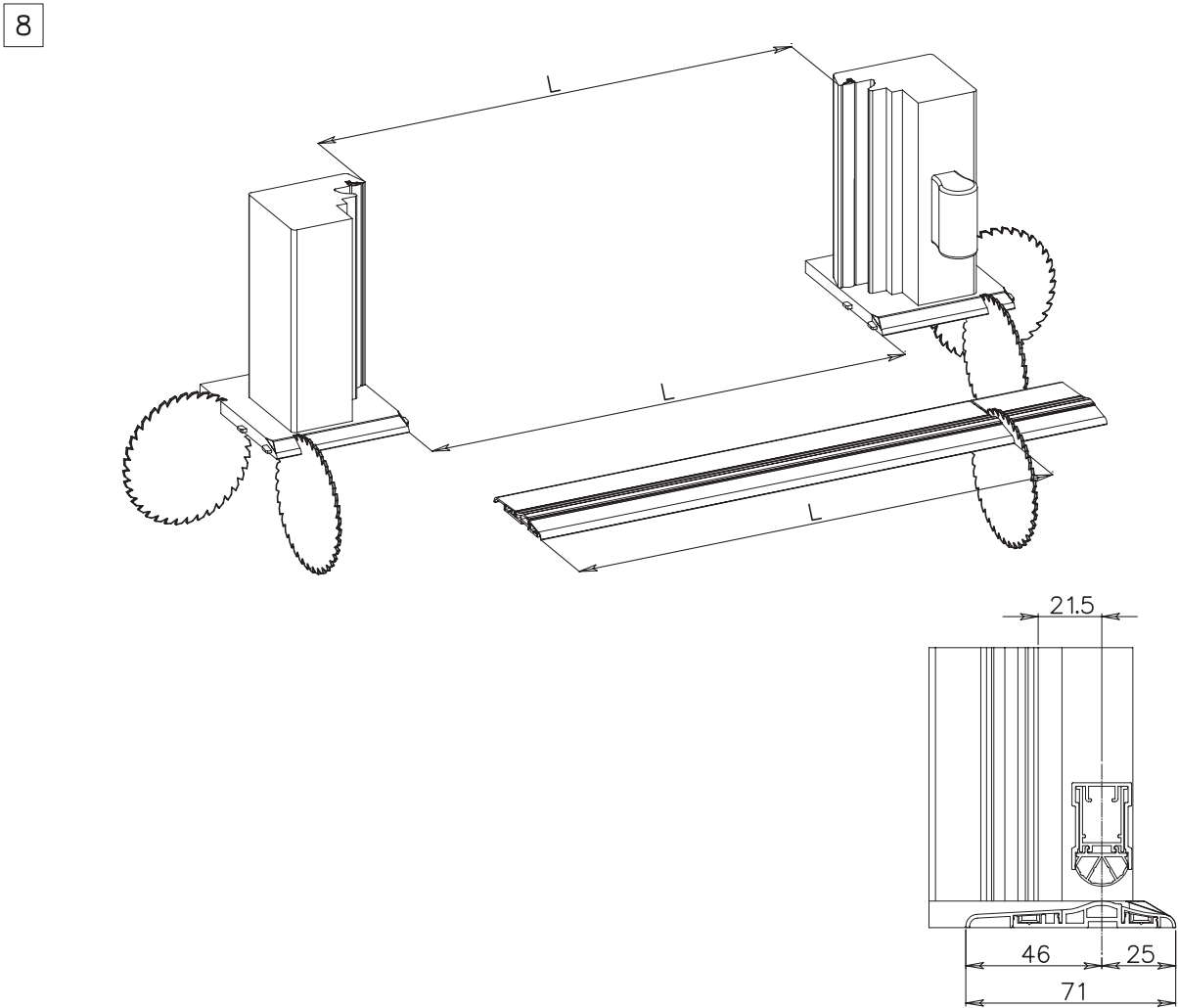
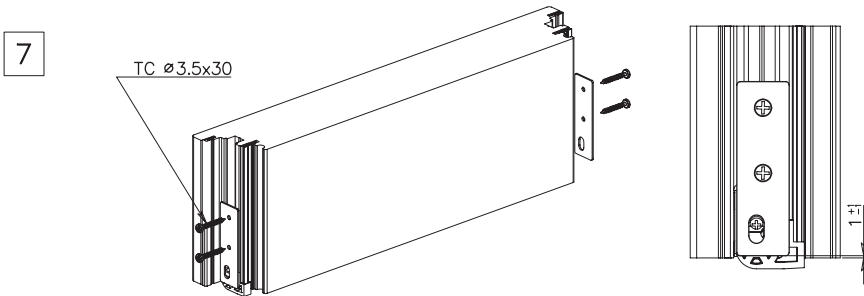
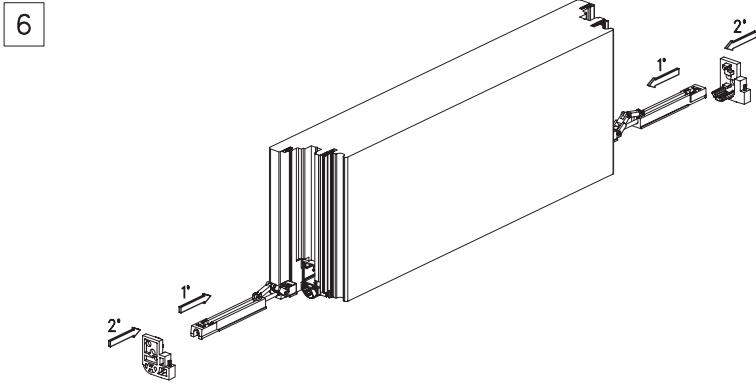

12 **Regolazione della pressione dei giunti sui sottomontanti, consigliata interferenza tra 0,5mm e 1mm**

