

SAFETY
DIVISION



CONDUCTIVE PRODUCTS
BROCHURE



SAFETY DIVISION

CONDUCTIVE EDGES

4

MAXXI CND

Safety contact edges for heavy sliding gates

MAXXI CND
MAXXI CND LINK CABLE
MAXXI CND LINK TERMINAL
MAXXI CND RADIO EVO

6

COMPATTA CND

Safety contact edges with compact size

COMPATTA CND
COMPATTA CND LINK CABLE
COMPATTA CND LINK TERMINAL
COMPATTA CND RADIO EVO

8

MINI CND

Safety contact edges with compact size

MINI CND

10

MINI ROLL CND

Safety contact edges for swing gates

MINI ROLL CND

12

MINI LIP CND

Safety contact edges for sectional doors

MINI LIP CND KIT
MINI LIP CND

14

PICCOLA CND

Safety contact edges for gates and industrial use

PICCOLA CND KIT
PICCOLA CND

16

PROFILO 30°

The 30° profile for a 360° safety

ACCESSORIES

18

SCHED2 & RADIO EVO

Control board and wireless transmission systems for safety edges

SCHED2
SCHEDSCAT
RADIO RX EVO 868 MHZ
RADIO TX EVO 868 MHZ

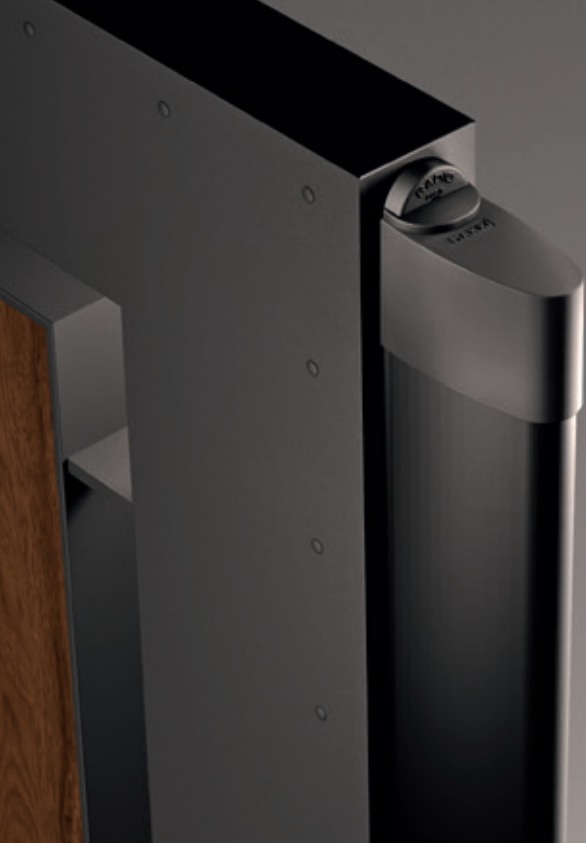

MAXXI CND

Safety contact edges for
large sliding gates

🇮🇹 Il pezzo forte della famiglia di bordi sensibili con tecnologia conduttiva, MAXXI CND è progettato per l'utilizzo su cancelli scorrevoli molto pesanti. Utilizza un profilo conduttivo in TPE coestruso al suo interno che garantisce risposte rapide ad ogni impatto, ed è accorciabile infinitamente.

🇬🇧 The showpiece of safety contact edges family, MAXXI CND has been designed to be used on heavy and large sliding gates. It features an inner TPE conductive profile which guarantees quick response to every impact, the bar can be trimmed at will.

🇫🇷 Au sommet de la famille des bords sensibles avec technologie conductive, MAXXI CND est conçue pour une utilisation sur les portails coulissants très lourds. Elle utilise à l'intérieur un profil conducteur coextrudé en TPE qui garantit des réponses rapides à chaque impact, elle est raccourcissable infiniment.

🇩🇪 MAXXI CND ist das Highlight der Kontaktleistenreihe mit Leitertechnologie und für sehr schwere Schiebetore konzipiert. Sie verwendet ein innenliegendes koextrudiertes TPE-Leitprofil, das sofort auf jedes Anstoßen reagiert, stufenlos ablängbar.

🇪🇸 El punto fuerte de la familia de bordes sensibles con tecnología conductora es MAXXI CND, que ha sido diseñado para el uso en puertas correderas muy pesadas. Utiliza un perfil conductor de TPE coextruido en su interior que garantiza respuestas rápidas en cada impacto, puede recortarse ilimitadamente.



**TOTAL
SAFETY**

Safety guaranteed on all
border's length, including
endcaps.

APPLICATIONS

SIZES

LENGTHS AND TRIMMING

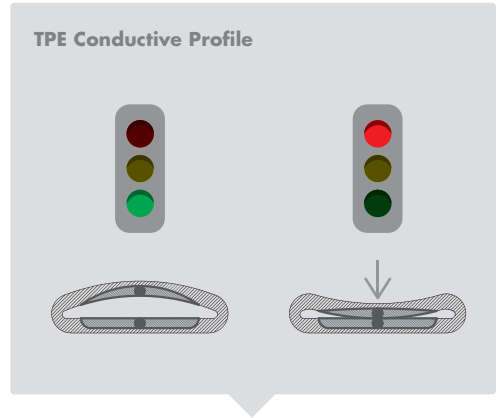
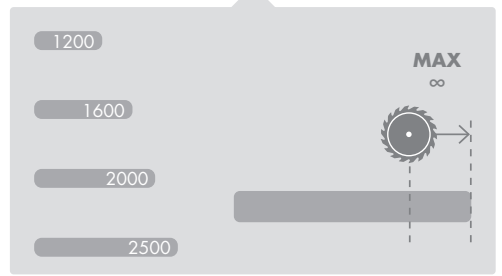
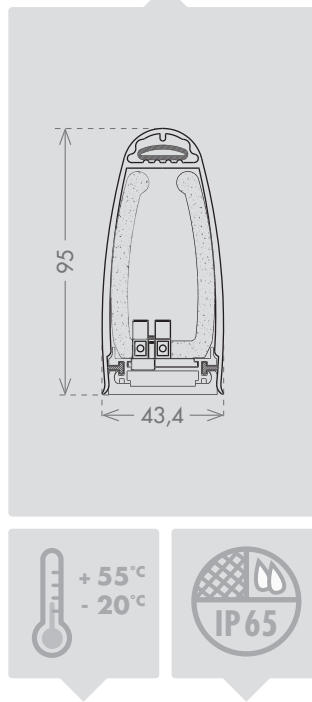
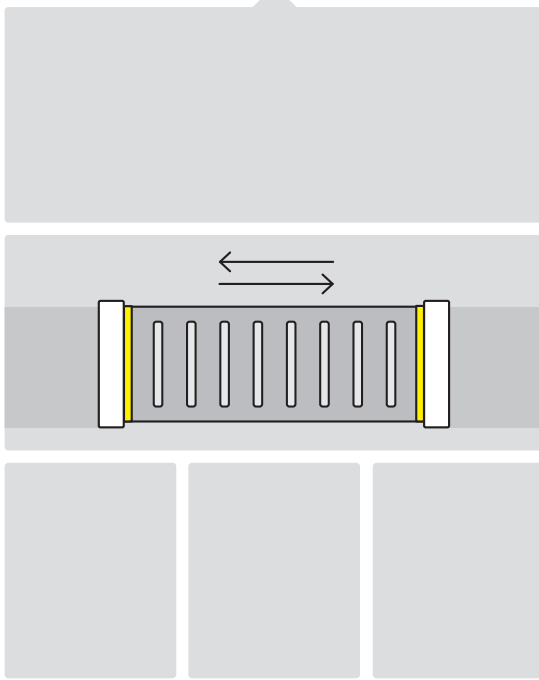

TEMPERATURE

DEVICE
IP RATING

TECHNOLOGY

MAXXI CND

code: **CEMACN00NO**



MAXXI CND LINK CABLE

code: **CEMACNLCNO**



MAXXI CND LINK TERMINAL

code: **CEMACNLTNO**



MAXXI CND RADIO EVO

code: **CEMACNRENO**







COMPATTA CND

Safety contact edges with compact size.

 Facile da installare ed accorciabile infinitamente, COMPATTA CND sfrutta la tecnologia conduttiva in un bordo sensibile piccolo e discreto. Il dispositivo di sicurezza garantisce una risposta rapida agli impatti su tutta la lunghezza della struttura.

 Easy to install, COMPATTA CND can be cut down at will. It uses an inner TPE conductive profile on a small and discreet body, which guarantees quick response to every impact.

 Facile à installer et raccourcissable infiniment, COMPATTA CND exploite la technologie conductive dans un format de bord sensible petit et discret. Le dispositif de sécurité assure une réponse rapide aux impacts sur toute la longueur de sa structure.

 COMPATTA CND ist einfach zu montieren, stufenlos ablängbar und nutzt in einer kleinen und diskreten Kontaktleiste die Leitertechnologie. Die Sicherheitseinrichtung garantiert das schnelle Reagieren auf alle Stöße entlang der gesamten Struktur.

 Fácil de instalar y recortable ilimitadamente, COMPATTA CND incorpora tecnología conductora en un borde sensible pequeño y discreto. El dispositivo de seguridad garantiza una respuesta rápida a los choques a todo lo largo de la estructura.



**TOTAL
SAFETY**

Safety guaranteed on all border's length, including endcaps.

APPLICATIONS

SIZES

LENGTHS AND TRIMMING

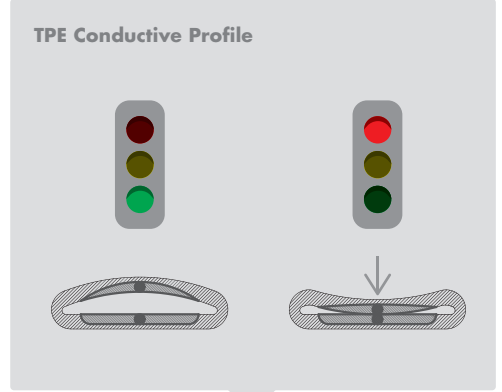
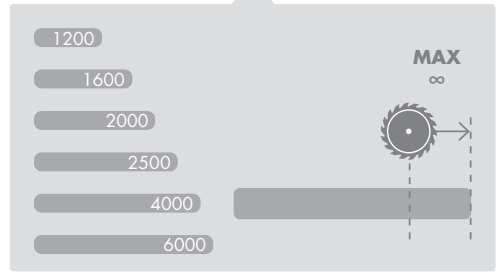
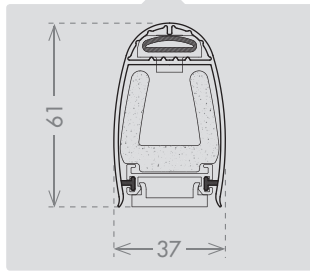
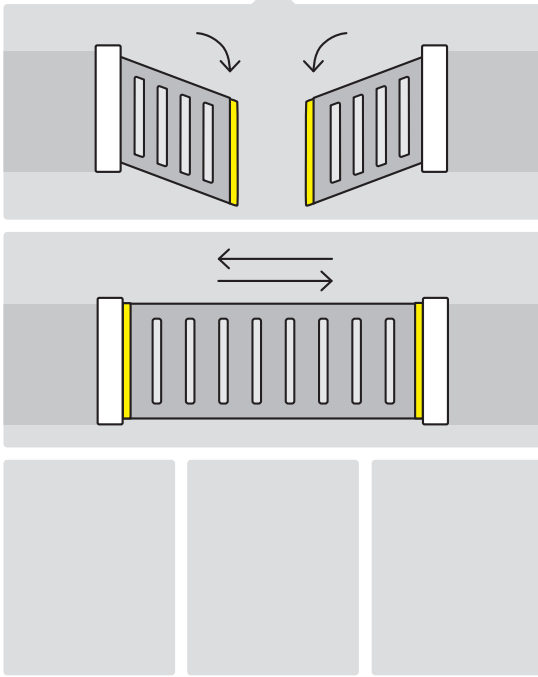

TEMPERATURE

DEVICE IP RATING

TECHNOLOGY

COMPATTA CND

code: **CECOCN00N0**

COMPATTA CND LINK CABLE

code: **CECOCNLCN0**



COMPATTA CND LINK TERMINAL

code: **CECOCNLTN0**

COMPATTA CND RADIO EVO

code: **CECOCNRENO**







MINI CND

Safety contact edges with compact size.

 Il modello MINI CND è stato progettato per l'utilizzo sui cancelli a battente, installato sul perimetro del cancello sia in posizione verticale che in posizione orizzontale. Utilizza un profilo conduttivo in TPE coestruso al suo interno che garantisce risposte rapide ad ogni impatto ed è accorciabile infinitamente.

 Model MINI CND is designed to be used on swing gates and installed on the perimeter of the gate both in vertical position and in horizontal position. It features an inner TPE conductive profile which guarantees quick response to every impact, the bar can be cut down at will at any length.

 Le modèle MINI CND a été pensé pour être installée sur le périmètre du portail aussi bien en position verticale qu'horizontale. Il utilise un caoutchouc conducteur en TPE co-extrudé qui garantit un temps de réponse rapide à l'impact et est recoupable indéfiniment.

 Das Modell MINI CND wurde für Drehtore ausgelegt und wird umlaufend montiert. Ein intern verlaufendes koextrudiertes Leiterprofil aus TPE ist beliebig ablängbar und gewährleistet das sofortige Ansprechen bei jeder Berührung.

 El model MINI CND fue ideado para ser utilizado en cancelas con bisagra, y puede ser instalado sobre el perímetro de la cancela tanto en vertical y en horizontal. Usa un perfil conduttivo con TPE coextruida al interior para garantir una reacción rápida a cada choque y puede ser acortado infinitamente.



**TOTAL
SAFETY**

Safety guaranteed on all border's length, including endcaps.



APPLICATIONS

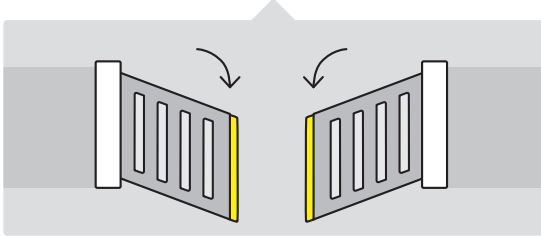

SIZES

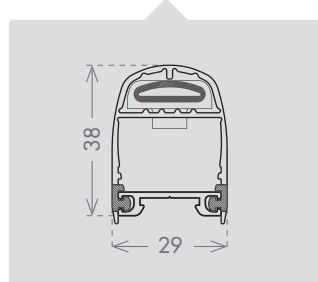

LENGTHS AND TRIMMING

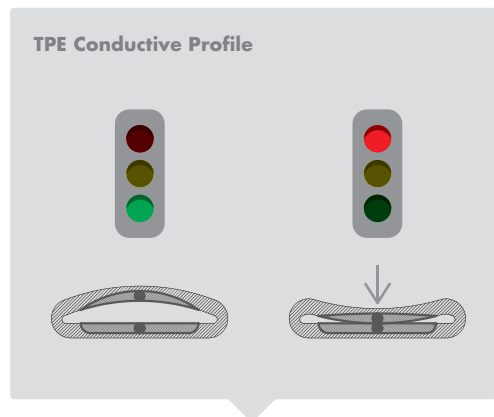
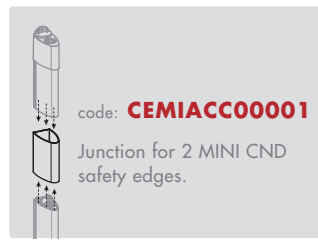
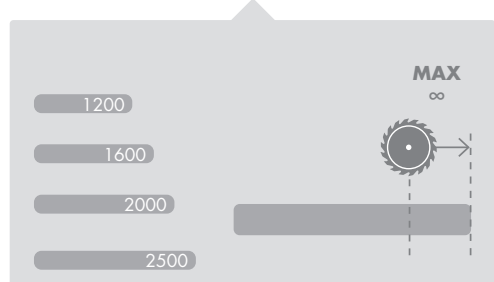

TEMPERATURE

DEVICE IP RATING

TECHNOLOGY

MINI CND

code: CEMICN00G0

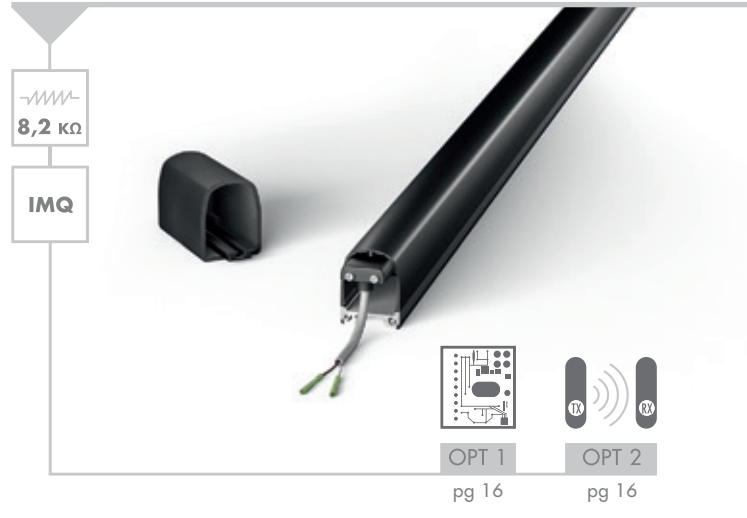





MINI ROLL CND

Safety contact edges for swing gates.

 Il modello MINI ROLL CND è stato progettato per l'utilizzo sui cancelli a battente, installato sul perimetro del cancello sia in posizione verticale che in posizione orizzontale. Utilizza un profilo conduttivo in TPE coestruso al suo interno che garantisce risposte rapide ad ogni impatto ed è accorciabile infinitamente. MINI ROLL CND è disponibile in comodi kit, pensati per poter comporre diversi spezzoni di lunghezza a piacimento.

 Model MINI ROLL CND is designed to be used on swing gates and installed on the perimeter of the gate both in vertical position and in horizontal position. It features an inner TPE conductive profile which guarantees quick response to every impact, the bar can be cut down at will at any length. MINI ROLL CND is available in a handy kit which includes all the necessary items to produce several segments of different lengths.

 Le modèle MINI ROLL CND a été pensé pour être installée sur le périmètre du portail aussi bien en position verticale qu'horizontale. Il utilise un caoutchouc conducteur en TPE co-extrudé qui garantit un temps de réponse rapide à l'impact et est recoupable indéfiniment. MINI ROLL CND Il est disponible en kit pratiques et conçus pour réaliser plusieurs palpeurs de longueurs variées.

 Das Modell MINI ROLL CND wurde für Drehtore ausgelegt und wird umlaufend montiert. Ein intern verlaufendes koextrudiertes Leiterprofil aus TPE ist beliebig ablängbar und gewährleistet das sofortige Ansprechen bei jeder Berührung. MINI ROLL CND Erhältlich als zweckmäßiges Set für das Zusammensetzen in beliebig lange Teile.

 El model MINI ROLL CND fue ideado para ser utilizado en cancelas con bisagra, y puede ser instalado sobre el perimetro de la cancela tanto en vertical y en horizontal. Usa un perfil conduttivo con TPE coextruida al interior para garantir una reacción rapida a cada choque y puede ser acortado infinitamente. MINI ROLL CND Es sidponible en kit ideado para construir piezas de diferente longitud.

 **TOTAL
SAFETY**

Safety guaranteed on all border's length, including endcaps.

APPLICATIONS

SIZES

LENGTHS AND TRIMMING

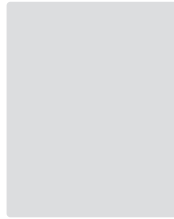
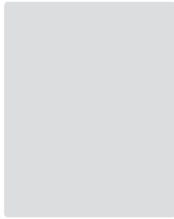
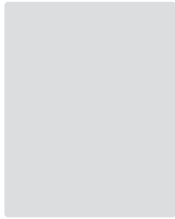
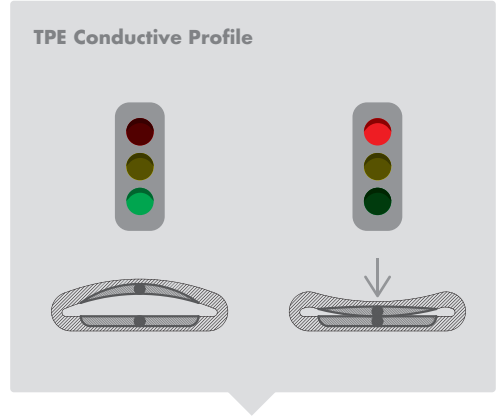
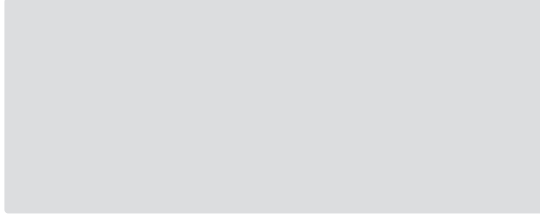
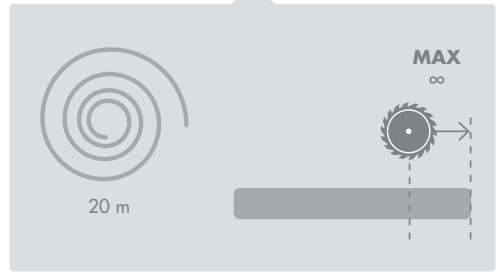
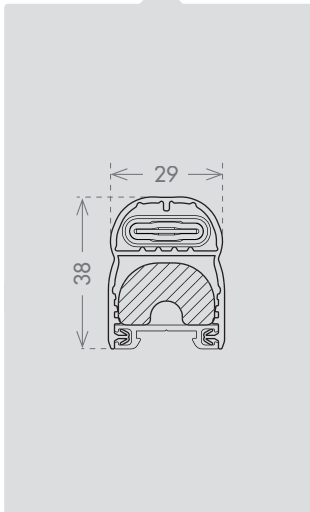
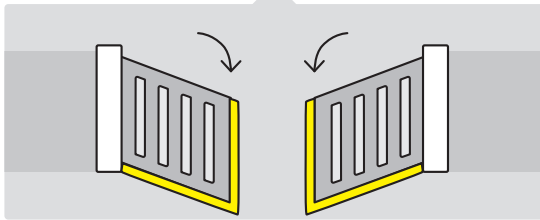

TEMPERATURE

DEVICE IP RATING

TECHNOLOGY

MINI ROLL CND

code: **CEKITCND0024 + CEKITCND0022 + CEKITCND0025A**

8,2 KΩ

IMQ

ESTIMATE FOR 10 KIT OF 2MT

20m

CEKITCND0024

2m x10

CEKITCND0022

x10

CEKITCND0025A

x10

OPT 1

pg 16

x10

OPT 2

pg 16

ACCESSORY:

code: **CESCHACC0024**



code: **CEKITCND0023**







MINI LIP CND

Safety contact edges for sectional doors.

 Il modello MINI LIP CND è l'ideale per l'applicazione in orizzontale su portoni sezionali e serrande. Grazie ai suoi tappi laterali con i fermi inclusi è molto semplice da regolare in fase di installazione. E' disponibile in comodi kit, pensati per poter comporre diversi spezzoni di lunghezza a piacimento.

 Model MINI LIP CND is the ideal horizontal application for sectional doors and rolling shutters. It features lateral endcaps with in-built adjusters for a perfect setup during installation. It's available in a handy kit which includes all the necessary items to produce several segments of different lengths.

 Le modèle MINI LIP CND est l'idéal pour une application horizontale sur portes sectionnelles et portes rideaux. Grâce à ses embouts latéraux avec fixation incluse, il est très facile à régler en phase d'installation. Il est disponible en kit pratiques et conçus pour réaliser plusieurs palpeurs de longueurs variées.

 Das Modell MINI LIP CND ist ideal für die horizontale Anwendung an Sektionaltoren und Rollläden. Dank seiner seitlichen Kappen und den dazugehörigen Feststelleinrichtungen ist seine Regulierung beim Anbringen sehr einfach. Erhältlich als zweckmäßiges Set für das Zusammensetzen in beliebig lange Teile.

 El model MINI LIP CND es ideal para una instalación horizontal sobre portones seccionales y cierres metálicos. Su tapones laterales con paradas incluidas permiten un ajuste muy fácil durante la instalación. Es sidponible en kit ideado para construir piezas de diferente longitud.



**TOTAL
SAFETY**

Safety guaranteed on all border's length, including endcaps.

APPLICATIONS

SIZES

LENGTHS AND TRIMMING

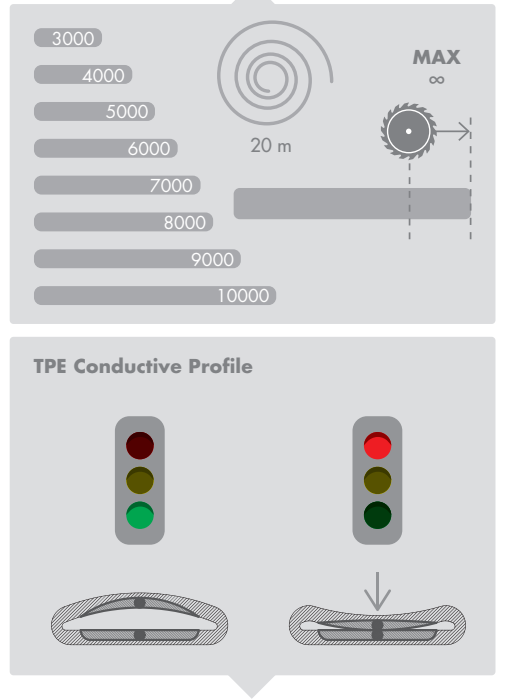
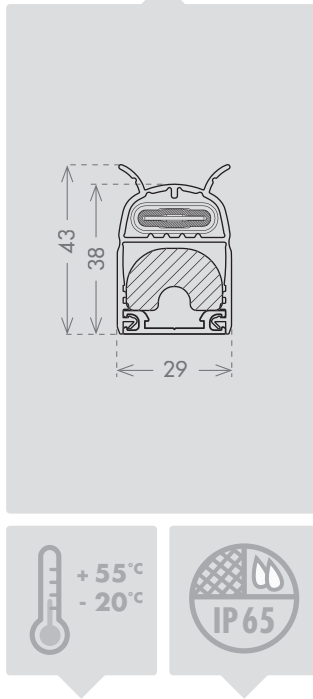
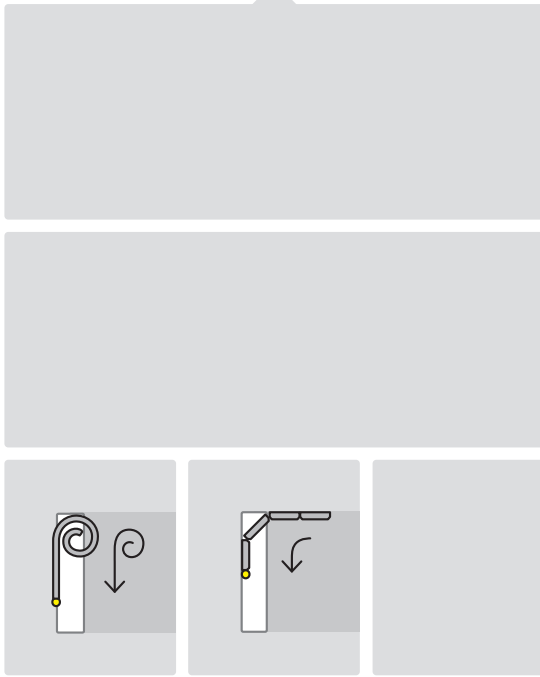

TEMPERATURE

DEVICE IP RATING

TECHNOLOGY

MINI LIP CND KIT

code: **CEKITCND0018 + CEKITCND0017 + CEKITCND0019A**

8,2 kΩ

IMQ

20m 2m x10 x5 x5 x5 x10

MINILIPBOX **MINILIPALU** **MINILIPCONN**

ESTIMATE FOR 5 KIT OF 4MT

OPT 1

pg 16

OPT 2

pg 16

ACCESSORY:

code: **CESCHACC0024**



MINI LIP CND

code: **CEMLCNOON**

8,2 kΩ

IMQ

ESTIMATE FOR 5 KIT OF 4MT

OPT 1

pg 16

OPT 2

pg 16





PICCOLA CND

Safety contact edges for gates and industrial use.

 Il modello PICCOLA CND può essere utilizzato sia sui cancelli a battente, per proteggere il punto di cesoiamento tra l'anta del cancello e lo stipite, sia nell'ambito industriale come bordo di sicurezza sui macchinari. E' disponibile sia in barre di misura finita che in comodi kit, pensati per poter comporre diversi spezzoni di lunghezza a piacimento.

 Model PICCOLA CND can be used on swing gates to protect the shearing point between the pillar and the gate leaf. It also can be used on industrial machinery as a safety edge for perimeter safety. It's available in bars or in a kit which includes all the necessary items to produce several segments of different lengths.

 Le modèle PICCOLA CND peut être utilisé aussi bien sur les portails battants pour protéger le point de cisaillement entre le vantail et le pilier que dans un environnement industriel en tant que bord de sécurité pour machines. Il est disponible soit en longueurs à mesure soit en kit conçu pour la réalisation de plusieurs palpeurs de longueurs variées.

 Das Modell PICCOLA CND kann sowohl auf Drehtoren angewendet werden, um den Scherpunkt zwischen dem Torblatt und dem Pfosten zu schützen, als auch im Industriebereich als Sicherheitsleiste an Maschinen. Erhältlich sowohl als fertige Stäbe als auch als bequeme Sets für das Zusammensetzen in beliebig lange Teile.

 El model PICCOLA CND puede ser utilizado tanto en cancelas con bisagra para proteger el espacio entre la hoja y el marco de la cancela, y tambien en aplicaciones industriales como dispositivo de seguridad en las maquinarias. Es disponible tanto en barras de misura definida, y en kit ideado para construir piezas de diferente longitud.



**TOTAL
SAFETY**

Safety guaranteed on all border's length, including endcaps.

APPLICATIONS

SIZES

LENGTHS AND TRIMMING

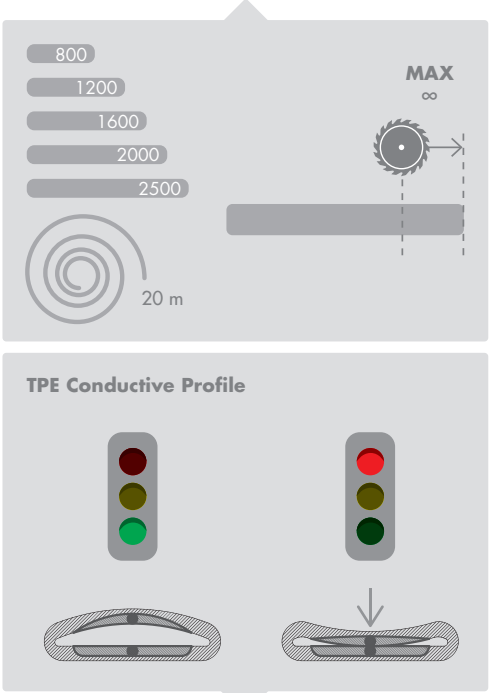
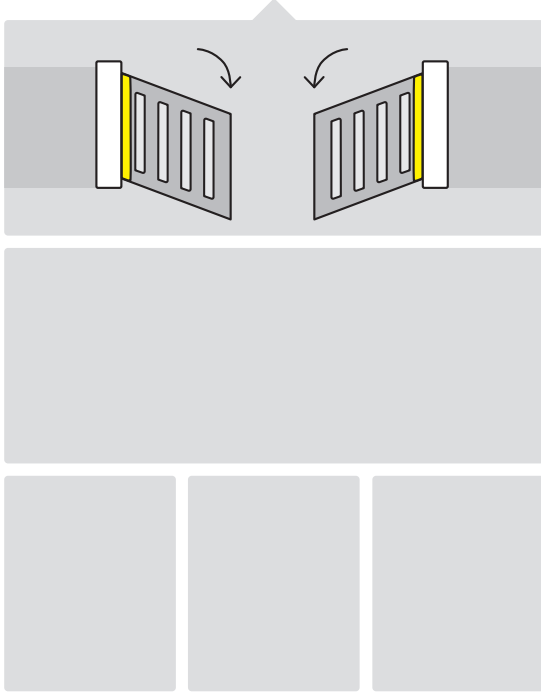

TEMPERATURE

DEVICE
IP RATING

TECHNOLOGY

PICCOLA CND KIT

code: **CEKITCND0002 + CEKITCND0001 + CEKITCND0003A**

8,2 kΩ

IMQ

PICCOBOX PICCOALU PICCOCONN

ESTIMATE
FOR 10 KIT OF 2MT

OPT 1
pg 16

OPT 2
pg 16

ACCESSORY:

code: **CESCHACC0024**



PICCOLA CND

code: **CEPICNO0N0**

8,2 kΩ

IMQ

ESTIMATE
FOR 10 KIT OF 2MT

OPT 1
pg 16

OPT 2
pg 16



PROFILO 30°

the 30° profile for a 360° safety

code: **CEDSACC00001 / CEDSACC00002**

🇮🇹 Il profilo inclinato migliora la sensibilità del bordo sensibile contro il pericolo di convogliamento. Abbinato al bordo sensibile COMPATTA riduce il gap tra anta scorrevole e punto fisso di 24 mm. Con MINI/MINIROLL su cancelli a battente permette di ridurre lo spazio tra l'anta e il suolo di 13 mm.

🇬🇧 The inclined profile increases the performance of the safety edge against the danger of conveyance. Combined with COMPATTA safety edge it reduces the gap between the leaf and the fixed element by 24 mm. With MINI/MINIROLL on swing gates, it reduces the space between the leaf and the floor by 13 mm.

🇫🇷 Le profil incliné augmente les performances de la bordure de sécurité contre le danger de transport. Associé au bord de sécurité COMPATTA, il réduit l'écart entre le vantail et l'élément fixe de 24 mm. Avec MINI/MINIROLL sur portails battants, il réduit l'espace entre le vantail et le sol de 13 mm.



🇩🇪 Das geneigte Profil erhöht die Leistung der Sicherheitskante gegen die Gefahr des Mitreißens. In Kombination mit der COMPATTA-Sicherheitskante verringert es den Abstand zwischen Flügel und festem Element um 24 mm. Mit MINI/MINIROLL an Drehtoren verringert es den Abstand zwischen Flügel und Boden um 13 mm.

🇪🇸 El perfil inclinado aumenta las prestaciones de la banda de seguridad contra el peligro de transporte. Combinado con la banda de seguridad COMPATTA reduce de 24 mm el espacio entre la hoja y el elemento fijo. Con MINI/MINIROLL en puertas batientes reduce de 13 mm el espacio entre la hoja y el suelo.

APPLICAZIONE SU CANCELLI SCORREVOLI
APPLICATION ON SLIDING GATES

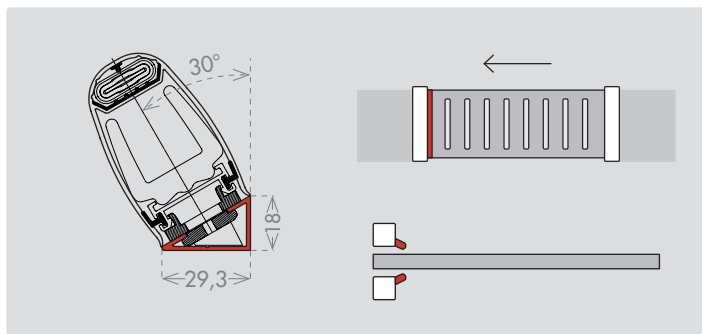

COMPATIBILE CON
COMPATIBLE WITH

COMPATTA CND
COMPATTA PROTO

MISURE DISPONIBILI
AVAILABLE SIZES

2000
 3000

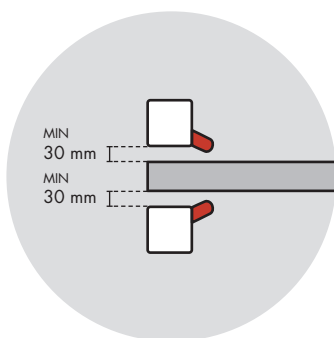

APPLICAZIONE SU CANCELLI A BATTENTE
APPLICATION ON SWING GATES

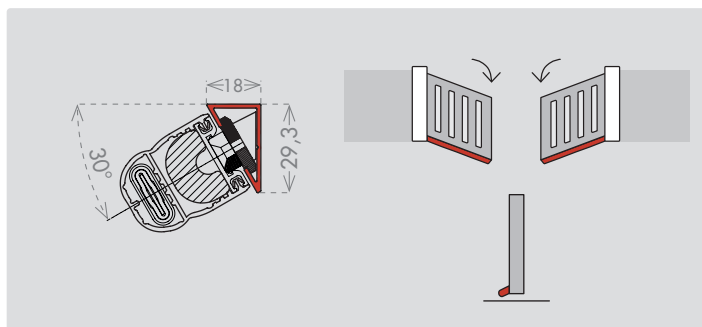

COMPATIBILE CON
COMPATIBLE WITH

MINI CND
MINIROLL CND

MISURE DISPONIBILI
AVAILABLE SIZES

2000
 3000

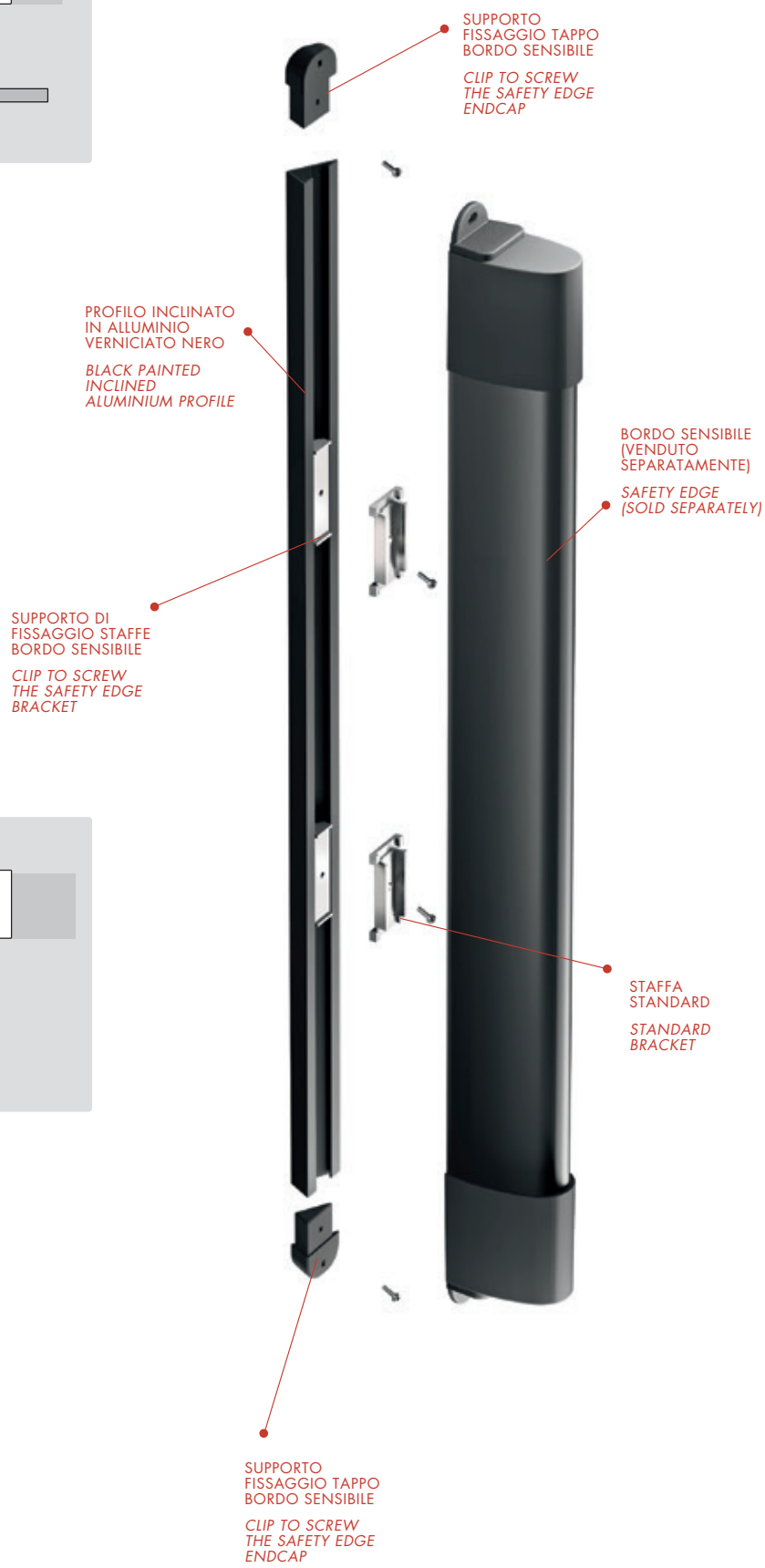
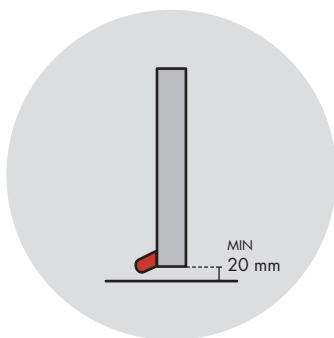

ACCESSORIES

SCHEMA DI CONTROLLO

code: **CESCHACC0012A (SAFETY CATEGORY 2 PL D)**

code: **CESCHACC0014A (SAFETY CATEGORY 3 PL E)**



SCATOLA

code: **CESCHACC0013A**



RADIO EVO RX 868MHZ

code: **CESCHACC0002A**

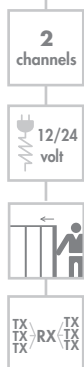

RADIO EVO TX 868MHZ

code: **CESCHACC0007A**



CERTIFICATIONS

COMPANY CERTIFICATION



Management System
ISO 9001:2015
ISO 14001:2015
ISO 45001:2018



www.tuv.com
ID 9105070522

IMQ CR 466 DM CERTIFICATION (CAT.2 PL "D")

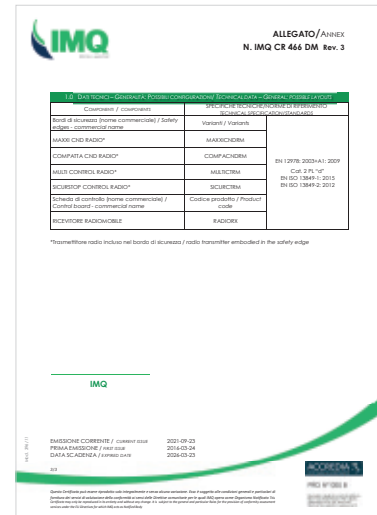
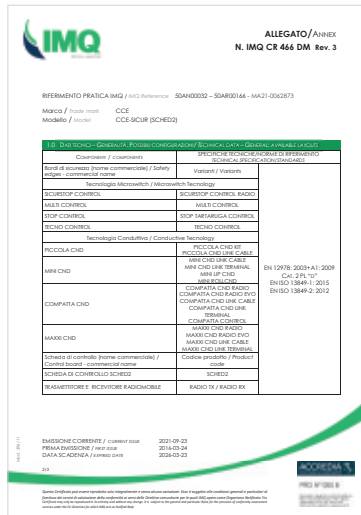

IMQ CT 496 DM CERTIFICATION (CAT.3 PL "E")



LEGENDA

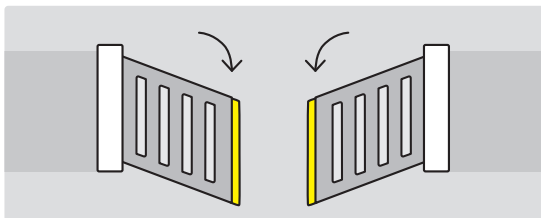

Cancelli a battente.
Swing gates.
 Portails battants.
Schwenktore.
 Puertas de hoja batiente.

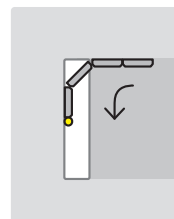

Portoni sezionali.
Sectional doors.
 Portes sectionnelles.
Sektionaltore.
 Portones seccionales.

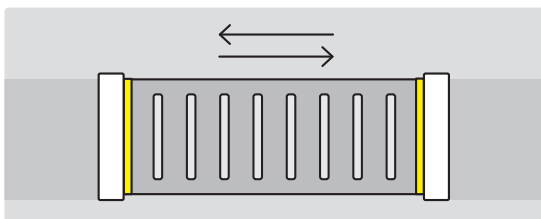

Cancelli scorrevoli.
Sliding gates.
 Portails coulissants.
Schiebetore.
 Puertas correderas.

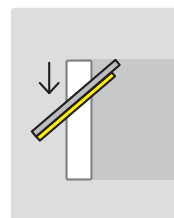

Portoni basculanti.
Overhead doors.
 Portes basculantes.
Kipptore.
 Portones basculantes.

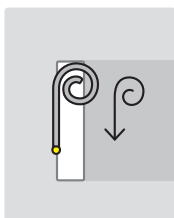

Serrande.
Rolling shutters.
 Rideaux.
Rolltore.
 Puertas enrollables.

CARATTERISTICHE GENERALI /GENERAL SPECIFICATIONS CARACTERISTIQUES GENERALES / ALLGEMEINE DATEN / CARACTERÍSTICAS GENERALES



Lunghezze disponibili.
Available lengths.
 Longueurs disponibles.
Verfügbare Längen.
 Largos disponibles.

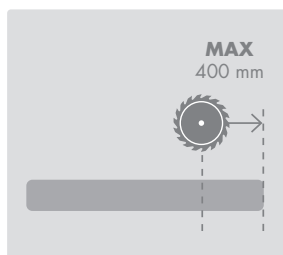

Accorciabilità massima.
Maximum trimming lengths.
 Raccourcissement maximum.
Maximale Ablängbarkeit.
 Recorte máximo posible.



Temperatura di esercizio.
Working temperature.
 Température de fonctionnement.
Betriebstemperatur.
 Temperatura de funcionamiento.



Grado di protezione microinterruttori.
Microswitch degree of protection.
 Indice de protection des micro interrupteurs.
Schutzart Mikroschalter.
 Grado de protección de los microinterruptores.

CARATTERISTICHE MODELLO / MODEL SPECIFICATIONS CARACTERISTIQUES PRODUITS / MODELLSPEZIFISCHE DATEN CARACTERÍSTICAS DEL MODELO



Contatto normalmente aperto (N.A.)
Normally open contact (N.O.)
Contact normalement ouvert (N.O.)
Schließerkontakt (N.O.)
Contacto normalmente abierto (N. A.)



Contatto normalmente chiuso (N.C.)
Normally closed contact (N.C.)
Contact normalement fermé (N.F.)
Öffnerkontakt (N.C.)
Contacto normalmente cerrado (N. C.)



Dispositivo di sicurezza resistivo.
Resistive safety edge.
Dispositif de sécurité résistif.
Widerstands-Schutzvorrichtung.
Dispositivo de seguridad resistivo.



Certificato IMQ.
Certificated by IMQ.
Certificat IMQ.
Zertifiziert durch IMQ als Prüfinstitut.
Certificación IMQ.



Portata massima in campo aperto.
Open field maximum range.
Portée maximum en champ libre.
Maximale Reichweite ungestört.
Alcance máximo en campo abierto.



Canali di trasmissione.
Nr. of transmission channels.
Canaux de transmission.
Übertragungskanäle.
Canales de transmisión.



Comanda fino a ... TX.
Controls up to ... Tx.
Contrôle jusqu'à ... TX.
Betätigung von bis zu ... Sendern.
Controla hasta ... TX.



Alimentazione con batterie al litio 1,5 V.
1,5V lithium batteries transmitter power supply.
Alimentation par piles au lithium 1,5 V.
Stromversorgung durch Lithiumakkus 1,5 V.
Alimentación con pilas de litio de 1,5 V.



Alimentazione 12/24 v AC/DC.
12/24 v AC/DC Power supply.
Alimentation 12/24 v AC/DC.
Betriebsspannung 12/24V AC/DC.
Alimentación: 12/24 VCA/VCC.



Frequenza di trasmissione.
Transmission frequency.
Fréquence de transmission.
Übertragungsfrequenz.
Frecuencia de transmisión.



Collegamento in serie di più coste conduttive.
Series wiring of several conductive safety edges.
Installation de plusieurs palpeurs conductif en série.
Reihenschaltung mehrerer Kontakteleiste
Conexión en serie de mas dispositivos CND.

OPZIONI / OPTIONALS OPTIONS / OPTIONEN / OPCIONES



Scheda di controllo.
Control boards.
Carte de contrôle.
Steuerkarte.
Tarjeta de control.



Coppia trasmettitore + ricevitore wireless.
Wireless receiver&transmitter.
Couple transmetteur et récepteur sans fil.
Funk-Sender-/Empfängeranlage.
Conjunto de transmisor + receptor inalámbrico.



Ricevitore wireless.
Wireless receiver.
Récepteur sans fil.
Funkempfänger.
Receptor inalámbrico.





Le immagini presenti in questo catalogo sono indicative e possono variare dagli articoli originali.
La C.C.E. srl si riserva il diritto di effettuare migliorie tecniche senza preavviso.

*The images on this catalogue are for displaying purposes only and can vary from the real item.
C.C.E. srl reserves the right to make technical upgrades without prior notice.*

Les images contenues dans ce catalogue sont indicatives et peuvent ne pas correspondre exactement aux articles d'origine.
L'entreprise C.C.E. srl se réserve le droit d'apporter toute modification technique sans préavis.

*Die in diesem Prospekt gezeigten Darstellungen sind unverbindlich, sie können vom Aussehen der Produkte abweichen.
C.C.E. behält sich das Recht zu technischen Verbesserungen ohne Vorankündigung vor.*

Las imágenes presentes en este catálogo son indicativas y pueden variar respecto a los artículos originales.
C.C.E. srl se reserva el derecho de efectuar modificaciones técnicas sin aviso previo.

C.C.E. srl
Costruzioni Chiusure Ermetiche

Via dell'Artigianato, 16
35010 Villa del Conte (PD) - ITALY
Tel. +39 049 9325073
Fax +39 049 9325384
www.cce.it
e-mail: safety@cce.it

